

doughXpress Model No.

D-TXM-2-18

Dual Heat Round Manual Dough Press



DIMENSIONS

Width: 22-1/2 inches, 57.2 centimeters
Height: 31-3/8 inches, 79.7 centimeters
Depth: 30-7/8 inches, 78.4 centimeters

WEIGHT

Press Only: 217 lbs.
Shipping: 235 lbs.

ELECTRICAL

220 Volt / 60 Hz
3100 Watts
15 Amps / Single Phase
15-6P NEMA Plug on 220v

EXTERIOR

Stainless Steel, Type 304
With #4 Polished Finish

The D-TXM-2-18 manual stainless steel model tortilla press is the most efficient, durable, and easiest way to press tortillas. With the large 18" dual heated platens, you can press, flatten, or par bake 4-6 tortillas in seconds. The bottom platen is lightweight and easily swings out so that you can quickly load and unload. It is also great for pizza dough too!

D-TXM-2-18 FEATURES INCLUDE:

- Large 18" platens.
- Heat both platens to 450°F or use it without heat for cold pressing.
- Easy-to-use digital temperature readout.
- Bottom swing out design saves space and is easier to use than top swinging models.
- Illuminated power On/Off buttons.
- Sleek, modern, durable, and easy to clean design. Available in Stainless Steel.
- Optional non-stick coated upper and lower platens.
- Quick lube fittings for easy maintenance.
- Ideal for pizzas, par baked pizzas, tortillas and paillards.
- NSF Listed.

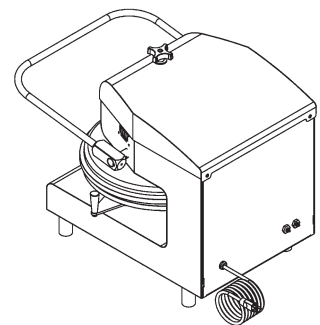
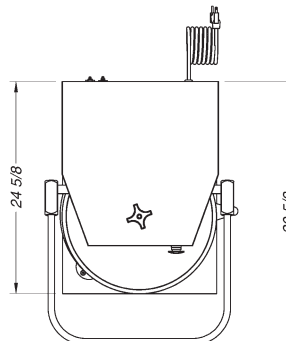
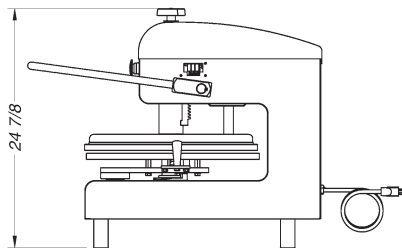
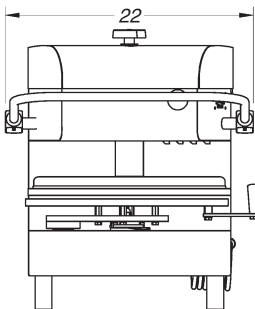

doughXpress
HIX Corporation Food Division
Product improvement may require us to change specifications without notice.
Revised April 2009

DOUGHXPRESS
1201 E. 27th Terrace
Pittsburg, KS 66762 USA

Toll Free: (800) 835-0606 ext.205
Tel: (620) 231-8568 ext.205
Fax: (866) 565-3189

doughxpress@hixcorp.com or visit www.doughxpress.com