

**doughXpress** Model No.

**TXA-SS**

**Air-Auto Tortilla Press**



Shown with optional  
Xylan® non-stick coating

**DIMENSIONS**

Width: 18 3/16 inches, 46.2 centimeters  
Height: 25-1/8 inches, 63.8 centimeters  
Depth: 24-11/16 inches, 62.7 centimeters

**WEIGHT**

Press Only: 217 lbs.  
Shipping: 235 lbs.

**ELECTRICAL**

220 Volt / 60 Hz  
3100 Watts  
15 Amps  
15-6P NEMA Plug

**AIR**

100-130 PSI Inlet, 1 CFM  
See Compressor Specifications (Separate).

**EXTERIOR**

Stainless Steel, Type 304  
With #4 Polished Finish

The TXA-SS air-automatic stainless steel model tortilla press is the most efficient, durable, and easiest way to press tortillas. With the large 16"x20" dual heated platens, you can press, flatten, or par bake 4-6 tortillas in seconds. The bottom platen is lightweight and easily swings out so that you can quickly load and unload. It is also great for pizza dough too!

**TXA-SS FEATURES INCLUDE:**

- Large 16"x20" grill sized platens.
- Heat one or both platens to 450°F or use it without heat for cold pressing.
- Easy-to-use digital temperature readout.
- Bottom swing out design saves space and is easier to use than top swinging models.
- Illuminated power On/Off buttons.
- Sleek, modern, durable, and easy to clean design. Available in Stainless Steel.
- Optional non-stick coated upper and lower platens.
- Quick lube fittings for easy maintenance.
- Perfect for flour or corn tortillas or pizza dough.
- NSF and CE Listed.

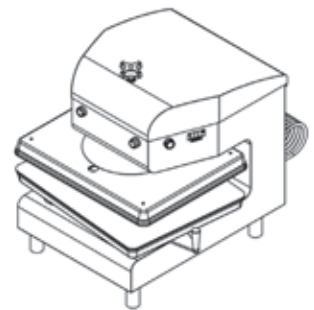
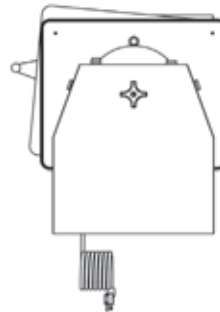
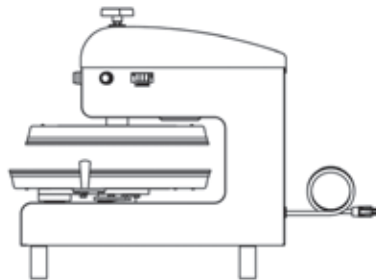
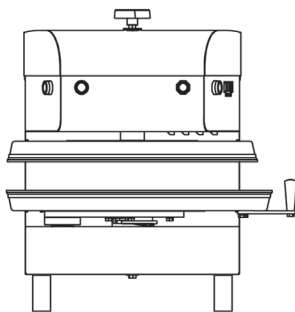

**doughXpress**  
**HIX Corporation Food Division**  
Product improvement may require us to change specifications without notice.  
Revised April 2009

DOUGHXPRESS  
1201 E. 27th Terrace  
Pittsburg, KS 66762 USA

Toll Free: (800) 835-0606 ext.205  
Tel: (620) 231-8568 ext.205  
Fax: (866) 565-3189

[doughxpress@hixcorp.com](mailto:doughxpress@hixcorp.com) or visit [www.doughxpress.com](http://www.doughxpress.com)