

doughXpress Model No.

TXM-15

Manual Tortilla Press



Shown with optional Xylan® non-stick coating

The efficient, economical, and durable TXM-15 is the 15 inch manual tortilla press with a swing away design for easy placement and removal of up to four tortillas. Works for either flour or corn tortillas, pizza dough and flat breads. Upper and lower platens heat to 450°F.

Discover the easy way to get fresh tortillas with consistent results in seconds.

TXM-15 Manual Tortilla Press Features:

- The 15"x15" dual heated platens can press, flatten, or par bake 2-4 tortillas in seconds.
- The heated platens help the dough flatten faster and easier, and they can also be used without heat for cold pressing.
- Optional non-stick coated upper and lower platens.
- The top platen swings away for easy loading and unloading of dough.
- Temperature control can be set from Off to 450°F.
- The heat indicating light will turn off when the set temperature is reached.
- Full range dough thickness adjustment.
- Easy to use open and close handle.
- Flattens tortillas into all sizes up to 15" in diameter.
- ETL & ETL Sanitation listed under same criteria as NSF.

DIMENSIONS

Width: 16-1/2 inches, 41.91 centimeters
Height: 15-1/4 inches, 38.74 centimeters
Depth: 24 inches, 60.96 centimeters

WEIGHT

Press Only: 68 lbs.

ELECTRICAL

220 Volts / 50-60 Hz
3,100 Watts
15 Amps
15-6P NEMA Plug on 220v

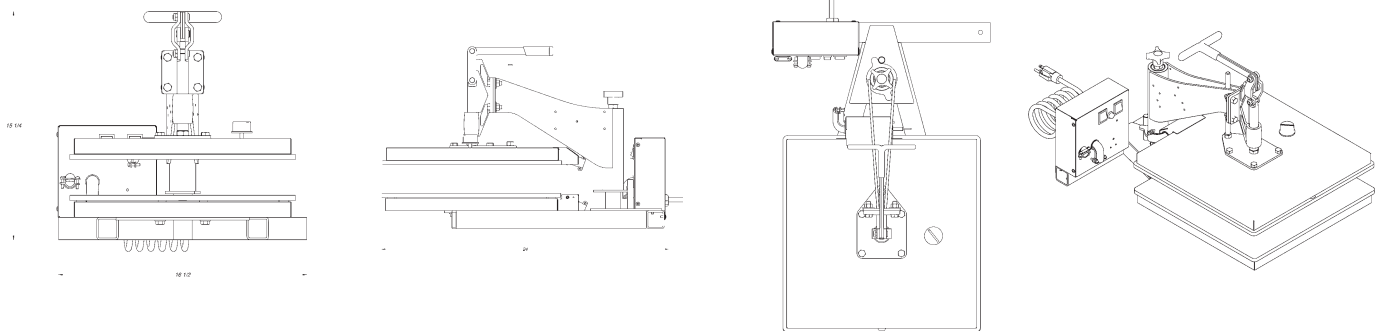

doughXpress
HIX Corporation Food Division
Product improvement may require us to change specifications without notice.
Revised April 2009

DOUGHXPRESS
1201 E. 27th Terrace
Pittsburg, KS 66762 USA

Toll Free: (800) 835-0606 ext.205
Tel: (620) 231-8568 ext.205
Fax: (866) 565-3189

doughxpress@hixcorp.com or visit www.doughxpress.com